

1 Dave and Fred are discussing issues about road safety.

(a) Look at the graph.

It shows data about the risks to road users.

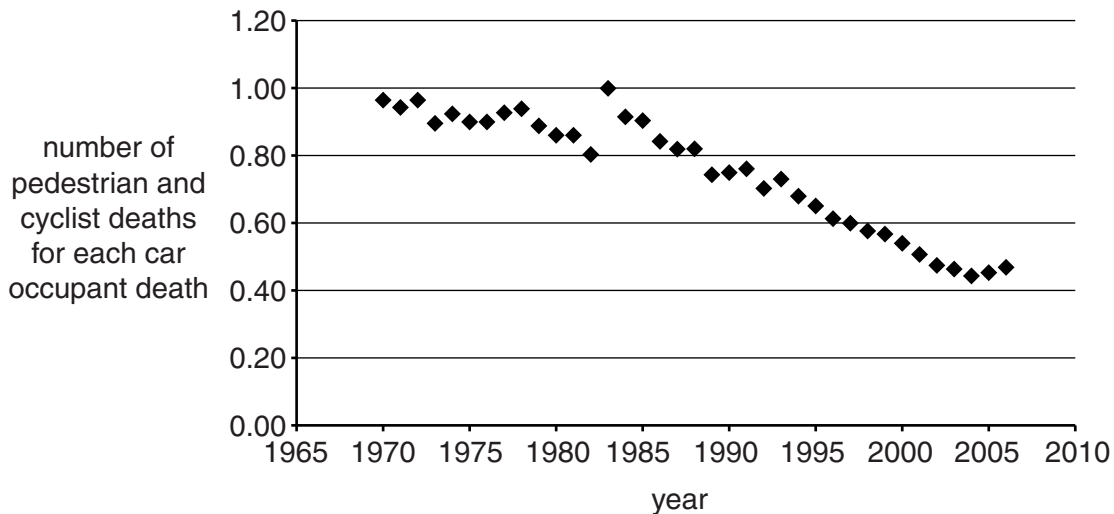

Dave thinks these data show that cycling has become safer since 1970, and that fewer cyclists die in accidents.

(i) Explain how the graph partly supports Dave's view.

.....
.....
..... [1]

(ii) Fred is less confident about what the data shows and feels he needs more information.

Suggest what other information about the data Fred needs to be more convinced.

.....
.....
.....
.....
.....
..... [2]

(b) Cars and their occupants have **momentum** when moving.

Seatbelts **stretch** in a crash.

Use these ideas to explain how seatbelts reduce injury in a crash.

.....

.....

.....

.....

..... [2]

[Total: 5]

2 Stopping distances are important for road safety.

The Highway Code uses diagrams to show stopping distances.

Look at the diagram.

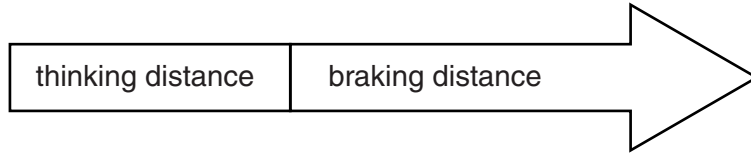

There are two parts to the stopping distance

- thinking distance
- braking distance.

Both of these can be **increased** by different factors.

Explain in detail how **road conditions**, **speed** and **alcohol** can affect road safety.



The quality of written communication will be assessed in your answer to this question.

.....

.....

.....

.....

.....

.....

.....

.....

.....

.....

.....

.....

.....

.....

.....

.....

.....

.....

.....

.....

.....

.....

.....

[6]

[Total: 6]

3 A car manufacturer tests a car to find out its mean fuel consumption.

Six different drivers drove the car 700m in a test drive.

The car was identical apart from the differences shown in the table.

driver	car windows	roof box fitted to car?	fuel consumption in kilometres per litre	CO ₂ emissions in grams per kilometre
A	closed	x	15.5	150
B	closed	x	17	140
C	open	✓	12	180
D	open	x	16	155
E	closed	✓	14.5	165
F	closed	✓	15.0	160

(a) Calculate the **mean** fuel consumption for the car from these results.

.....

answer kilometres per litre [1]

(b) Look at the fuel consumption data in the table.

One of the test drives produced a value well below the mean compared to the others.

This is partly due to increased drag.

Which driver is this? Choose from **A, B, C, D, E** or **F**.

.....

Identify what causes the increased drag **and** explain how this and **other** factors, lead to the poor fuel consumption.

.....

 [3]

[Total: 4]

4 Cars have many safety features such as crumple zones.

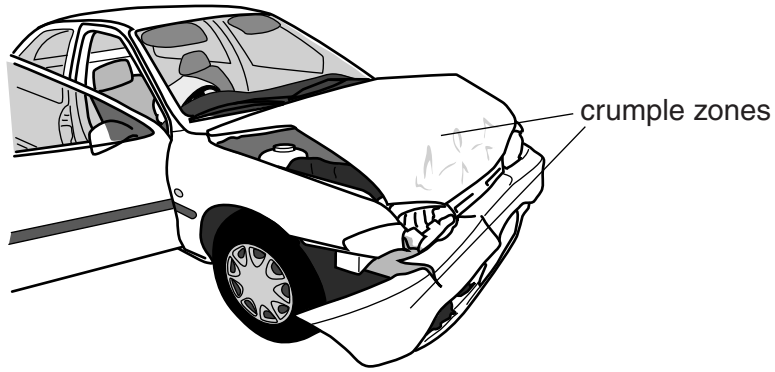

Crumple zones help to protect the occupants if a car is involved in a crash.

Car manufacturers continually try to improve safety features for drivers and passengers.

Explain in detail how crumple zones work and describe how manufacturers test crumple zones and use the results to improve future car design.



The quality of written communication will be assessed in your answer to this question.

.....

.....

.....

.....

.....

.....

.....

.....

.....

.....

.....

.....

.....

.....

.....

.....

.....

.....

.....

.....

.....

.....

[6]

[Total: 6]

5 Trevor wants to buy a new car.

The salesperson at his local garage gives him a brochure with information about some cars.

He looks at the information about five cars **V, W, X, Y** and **Z**.

car	engine size / capacity in cm ³	top speed in km per hour	time to accelerate from 0–90 km/hr in seconds	fuel consumption in kilometres per litre	CO ₂ emissions in grams per kilometre	noise level in decibels
V	1800	201	5.0	16.9	170	72.9
W	1400	177	7.4	17.3	165	71.3
X	1600	193	6.2	16.1	169	71.5
Y	1000	145	9.3	18.5	132	69.8
Z	1200	171	7.2	19.2		71.0

Trevor wants to buy the car that is most economical and does the least harm to the environment.

He talks to the salesperson.

Car X has the best fuel consumption and is quiet and I like the performance figures for car V.



Trevor

I don't think either car is the best one for you. You're misinterpreting some of the information. I would suggest car



Salesperson

(a) Explain how Trevor has misinterpreted the information and suggest, with reasons, which car he should buy to meet his requirements.

.....

.....

.....

.....

.....

.....

.....

.....

.....

.....

.....

[3]

(b) (i) Trevor test drives one of the cars. It has a weight of 12 000 N.

He drives with a net driving force of 500 N for a distance of 850 m during part of the drive.

This produces the maximum engine power and takes a time of 35 seconds.

Calculate the **power**.

Write your answer in kilowatts, **rounded** to the nearest kilowatt.

.....
.....
.....
.....

answer kW [2]

(ii) This represents the highest power of all of the 5 cars.

Use the information in the table to explain which car Trevor test drove.

Assume the mass of each car increases with engine size.

.....
..... [1]

(c) Trevor's friend John lives in the centre of a city.

John is considering buying an electric vehicle to drive on the inner city roads.

Look at the two examples of electric vehicles.

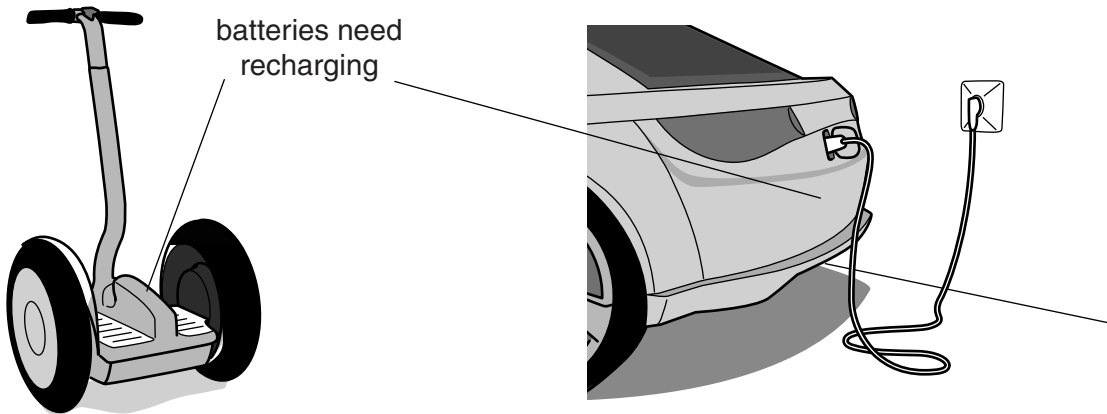

Electric powered vehicles could increasingly replace petrol driven cars.

Discuss the implications for **drivers** and **pedestrians** if this happens.

.....

.....

.....

.....

.....

.....

.....

[2]

[Total: 8]

6 The police take measurements after some road accidents.

They can measure the braking distance by measuring the length of the skid marks on the road.

This can give them an estimate of the original speed of the vehicles.

Look at the graph of a car stopping.

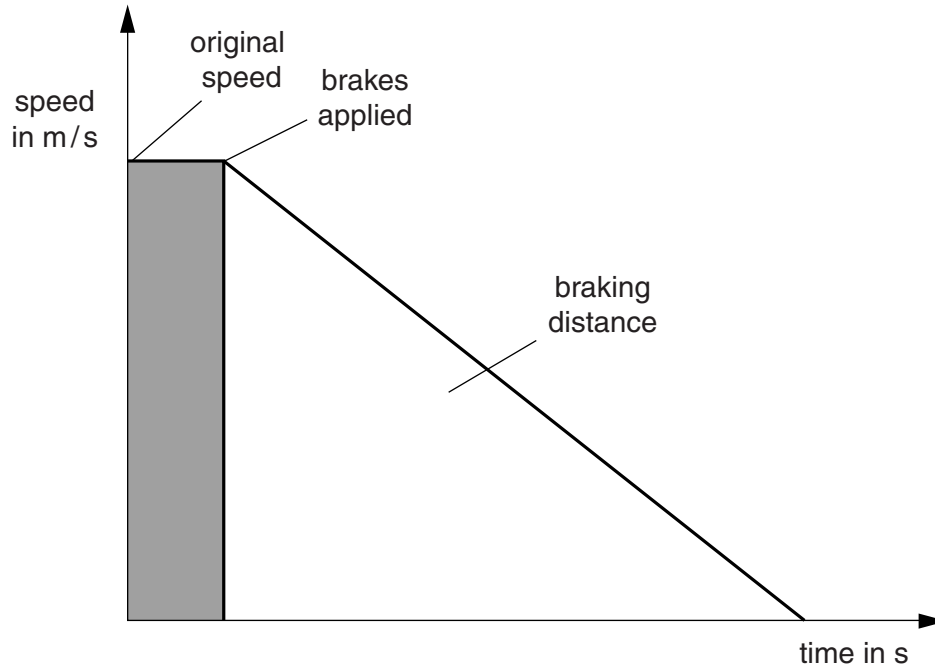

The car takes 5 s to brake and the skid mark is 75 m long.

(a) Calculate the **original** speed of the vehicle using this distance.

.....
.....

answer m/s [2]

(b) The speed limit is 32 m/s.

The police are not sure if the driver was travelling at a higher speed than the speed limit.

Suggest why the skid mark may **not** give an accurate estimate of the original speed of the driver.

.....
.....
..... [2]

(c) Police know that braking distances are related to speed.

This is because kinetic energy is transferred in braking.

Look at the diagram.



(i) Car **A** and car **B** are travelling at the same speed.

Car **A** has double the mass of car **B**.

Compare the amount of kinetic energy of car **A** and car **B**.

..... [1]

(ii) What happens to the kinetic energy of car **A** when its **speed** is doubled?

.....
..... [1]

(iii) What happens to the braking distance when the speed is doubled?

.....
..... [1]

[Total: 7]